

HD44 Connector at Front Panel (user signals)

z NoPART: iStamping: PCB Can for Db25-Hd44 Conn, gwi file: EMIShield-HD44
 i4xx RFI Conn Shield, 4 sides, solders to pcb
 S1111

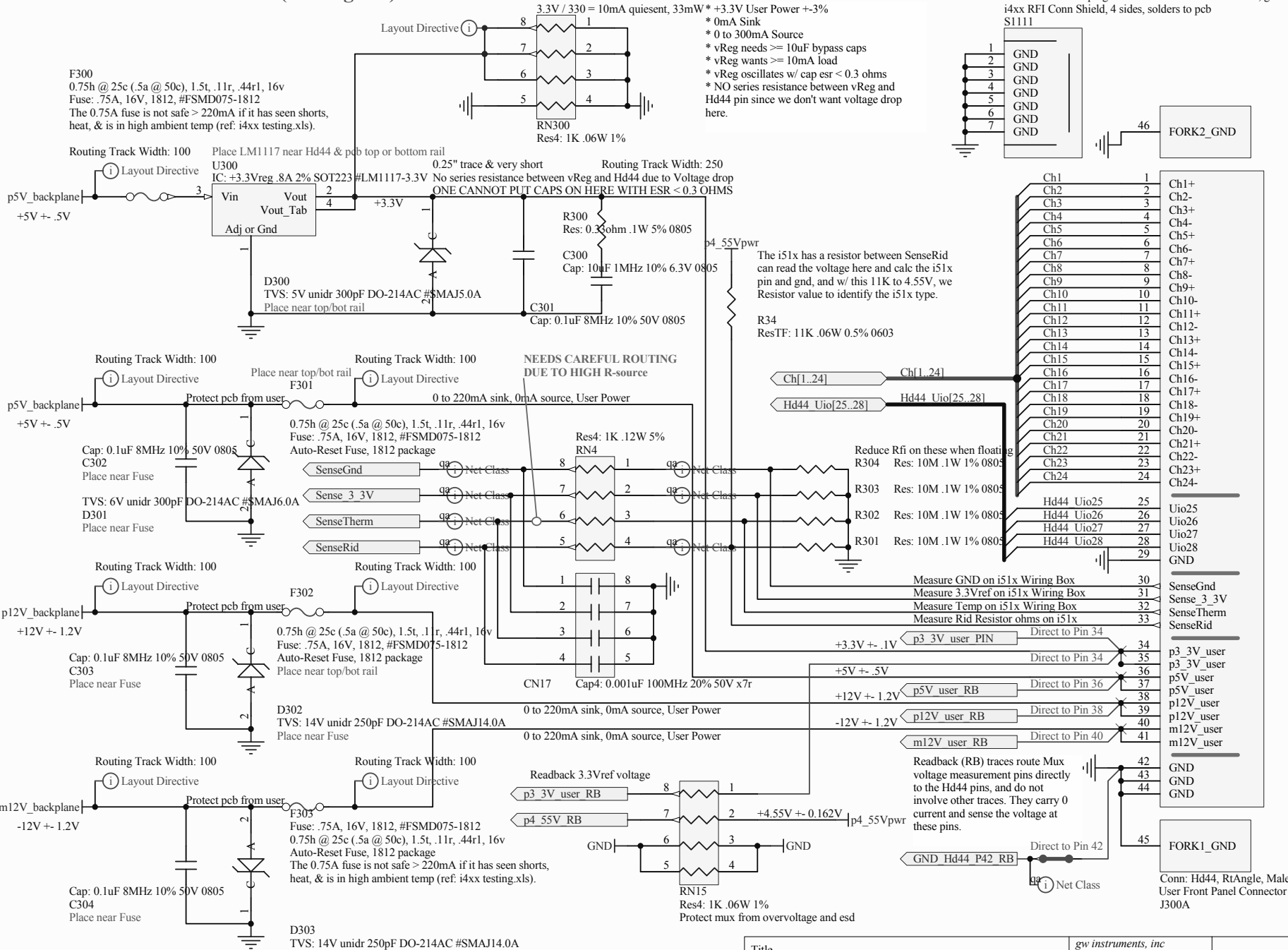

Title			gw instruments, inc
Size: Letter			35 medford st.
Number:			somerville, ma 02143, USA
Revision:			www.gwinst.com
Date: 3/5/2009	Time: 2:21:55 PM	Sheet 301of	
File: C:\Documents and Settings\Owner\My Documents\GWI\gwi Dev\iNet-4xx 2004 Design\i4xx schematics\i4xx Common Schematics\Common F			

