

4x Din/Dout Bits

Fpga IC
To/From Fpga IC...

Schmitt Trigger
(14 VCC = 3.3V, 2/.8Vin)

Protect '14 from Vin > Vcc

Place Diodes Close to LVC14

Pull Up to 5V when not driven

Series Protection
(+32V protection)

Hd44 User Connector
(Digital Control I/O Bits)

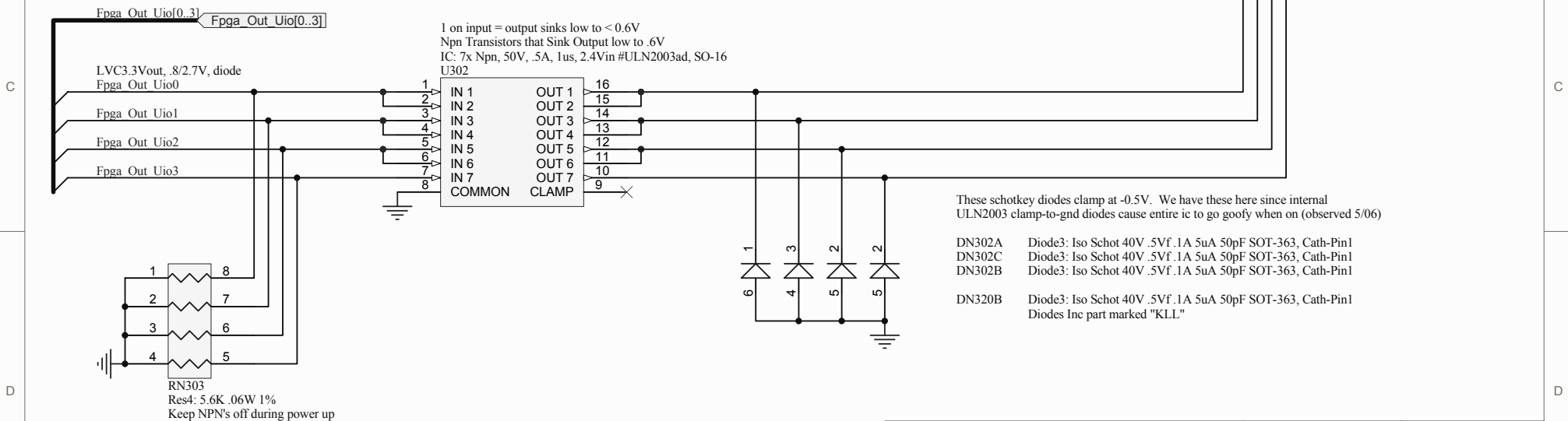
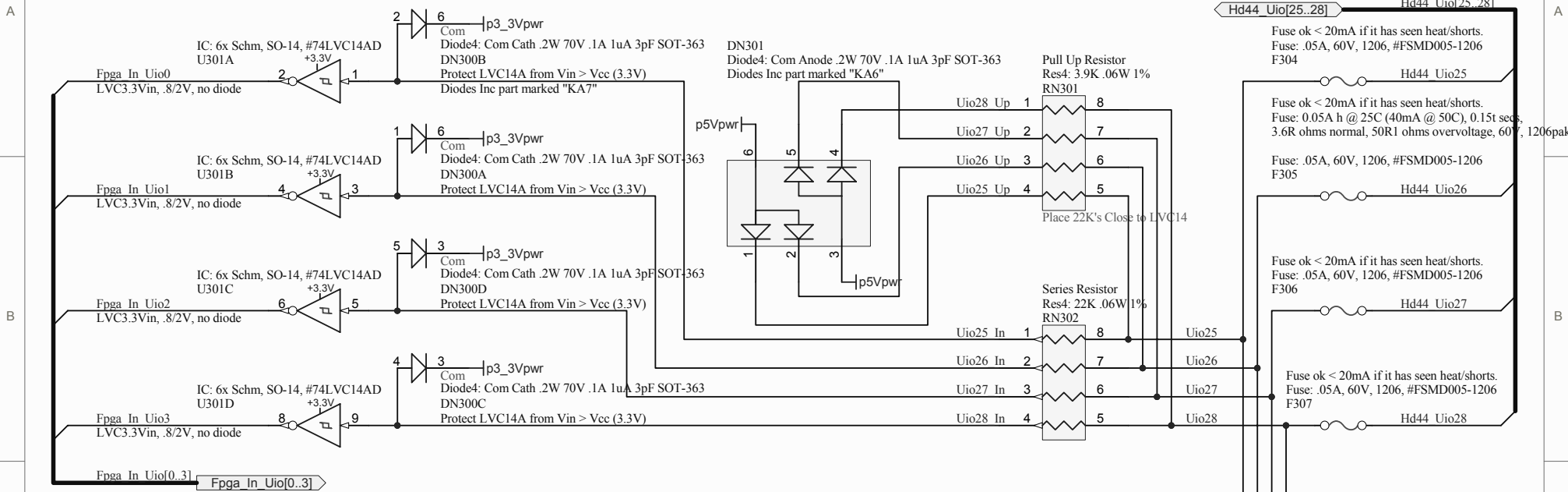

Title			gw instruments, inc 35 medford st. somerville, ma 02143, USA www.gwinst.com	
Size: Letter	Number:	Revision:	gwi	
Date: 3/5/2009	Time: 2:22:17 PM	Sheet 302of		
File: C:\Documents and Settings\Owner\My Documents\GWI\gwi Dev\iNet-4xx 2004 Design\i4xx schematics\i4xx Common Schematics\Common F				