

Buffer Amplifier, Vin = 0 to 5V, Vout = 0V to +10V, 5mA, Protected against short to +-24V

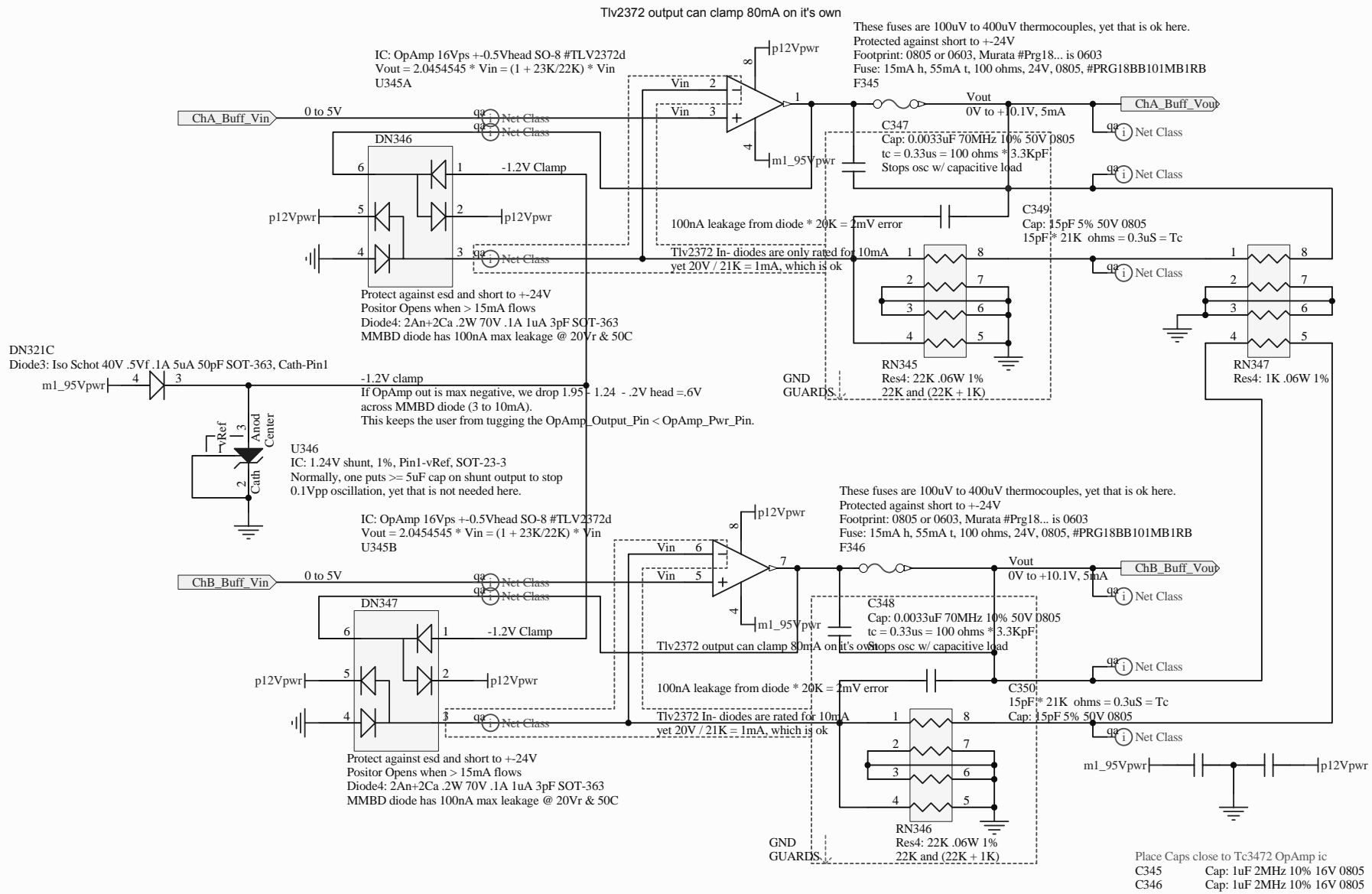

Title			gw instruments, inc 35 medford st. somerville, ma 02143, USA www.gwinst.com
Size: Letter	Number:	Revision:	gwi
Date: 3/5/2009	Time: 2:22:56 PM	Sheet 345of	
File: C:\Documents and Settings\Owner\My Documents\GWI\gwi_Dev\iNet-4xx 2004 Design\i4xx schematics\i4xx Common Schematics\Buffer Am			